

OmniCure® AC9 Series User Guide

Applicable for the following UV LED Head models:

Model	Array Curing Width	Part Number
AC9150-395	150 mm	019-00241R
AC9150P-395	150mm	019-00252R
AC9225-395	225 mm	019-00255R
AC9225P-395	225 mm	019-00253R
AC9300-395	300 mm	019-00247R
AC9300P-395	300 mm	019-00246R
AC9225F-395	225mm	019-00356R



Excelitas Canada Inc.
2260 Argentia Road
Mississauga (ON)
L5N 6H7 Canada
+1 905.821.2600
www.excelitas.com

Installation/Reference Guide
035-00621R
Excelitas Canada Inc. 2022
All rights reserved

No part of this publication may be reproduced, transmitted, transcribed, stored in a retrieval system or translated into any language in and form by any means without the prior written consent of Excelitas Canada Inc. Every effort has been made to ensure information in this manual is accurate; however, information in this manual is subject to change without notice and does not represent a commitment on the part of the authors.

Revision History

Revision #	Comments
Rev .0	Initial release ACg Series
Rev.1.0	Update LVD revision year and China RoHS section
Rev. 2.0	Addition of ACg225F
Rev. 3.0	Update to regulatory section
Rev. 4.0	Update to regulatory section

Table of Contents

1	Introduction	1
2	Safety Precautions/ User Warnings	2
2.1	Glossary of Symbols:	2
2.2	Safety Precautions:	3
3	Optical Safety Data	4
4	Getting Started	5
4.1	Packaging Contents	5
4.2	System Requirements	5
4.3	Connecting the Power Supply and PLC Controller.....	6
4.4	Powering Up and Powering Down	7
5	Mounting the UV Head	8
5.1	UV LED Head	8
5.2	Mounting the UV LED Head	8
5.3	Adjusting the Side Reflectors	9
5.4	UV LED Head Dimensions	9
6	Connecting the UV LED Head	12
6.1	Interfacing with the System Controller (PLC)	12
6.2	Integrating Monitoring with External Circuitry	13
6.3	Interfacing with the Power Cable	13
7	Using the LED Head	15
7.1	Understanding the LED Indicators	15
7.2	Fault Status.....	16
8	Troubleshooting	17
8.1	Symptoms and Possible Causes.....	17
9	Care and Maintenance	18
9.1	Cautions and Handling	18
9.2	Cleaning Materials.....	19
9.3	Cleaning the LED Head.....	19
9.4	Cleaning the LED Head Air Intake.....	19
10	Technical Specifications	20
10.1	Environmental Conditions	20
10.2	UV LED Head Specifications	20
10.3	Regulatory Compliance	21
10.4	China RoHS	21
10.5	WEEE Directive	22
11	Accessories	23
12	Warranty	24
12.1	Checking Your Lamp Hours	24
12.2	Replacement UV LED Module Warranty	25
12.3	Returning your AC9- System to Excelitas Technologies for Service	25
13	Contact Information	26

Figures

Figure 1 UV LED Head Connection Ports.....	6
Figure 2 UV LED Head.....	8
Figure 3 AC9300 UV LED Head Mechanical Drawings.....	10
Figure 4 AC9225 UV LED Head Mechanical Drawings.....	11
Figure 5 AC9150 UV LED Head Mechanical Drawings.....	11
Figure 6 PLC Connector (looking at UV Head).....	12
Figure 7 PLC Digital Output Equivalent Circuit.....	13
Figure 8 Power Connector (looking at UV Head).....	13

Tables

Table 1 PLC Connector Pin Out.....	13
Table 2 Power Connector Pin Out.....	14
Table 3 LED Indicator Status (UV LED Head).....	15
Table 4 Environmental Conditions.....	20
Table 5 UV LED Head Specifications.....	20
Table 6 UV LED Warranty Status.....	24

1 Introduction

The OmniCure® AC9-series-series represents a new standard in UV LED curing systems. The series provides unsurpassed levels of power, irradiance performance, control and monitoring in a compact form factor. The OmniCure® AC9-series systems are offered alongside a variety of power supply, controller and cabling options, providing configuration flexibility to suit any application for end users and integrators alike.

Optical output is controlled via a PLC interface enabling a high degree of automation. At the heart of the OmniCure® AC9-series are the arrays of LEDs housed within the UV LED Head and located under the optical lens providing excellent spectral and power stability. The UV LED Head has a typical lifetime in excess of 20,000 hours of accumulated 'on' time, made possible by the integration of state-of-the-art electronics, effective thermal management and high performance optics. Acoustic noise is minimised through an innovative load-adaptive fan that keeps the LEDs operating efficiently and reliably while minimising the resultant noise levels.

In the OmniCure® family of UV LED light systems, all systems offer the same high level of innovation, quality and reliability that our customers have come to expect. Since 1984, OmniCure® has combined next generation optical engineering, state-of-the art electronics and fibre-optics to produce sophisticated technologies that employ light. Today, OmniCure® is a leading developer of light-based systems for sectors ranging from manufacturing to bio-medicine, and is unmatched in our commitment to quality and service.

This manual covers the following models:

Model	Array Curing Width	Part Number
AC9150-395	150 mm	019-00241R
AC9150P-395	150mm	019-00252R
AC9225-395	225 mm	019-00255R
AC9225P-395	225 mm	019-00253R
AC9300-395	300 mm	019-00247R
AC9300P-395	300 mm	019-00246R
AC9225F-395	225mm	019-00356R

Excelitas Technologies recommends reading this guide to discover all features of the OmniCure® AC9-Series systems, and how to use them.

2 Safety Precautions/ User Warnings

2.1 Glossary of Symbols:



Caution risk of danger – consult accompanying documents.



Risk Group 3 (IEC62471)

WARNING: UV emitted from this product. Avoid eye and skin exposure to unshielded product.

CAUTION: Possibly hazardous optical radiation emitted from this product. Do not stare into operating lamp.



Input/ Output Signals



Input Signal



Caution, Hot Surface



Protective Conductor Terminal



Earth (Ground) Terminal



CAUTION, Risk of Electrical Shock

2.2 Safety Precautions:

This series of cautions and warnings relate to the installation, operation and maintenance of the OmniCure® AC9- System. They are also presented throughout this Installation/Reference Guide as applicable.



WARNING

Do not stare directly at the light emitted from the LED array. This may be harmful, resulting in eye injury. Always use UV protective eyewear as indicated below. Additionally, protect any exposed skin with appropriate clothing or shielding as required.



Warning UV protective eyewear must meet the following recommended optical specifications:

- Spectral range; 350-440nm
- Optical Density ≥ 6



Warning Should the OmniCure® AC9- System be used in a manner not specified by Excelitas Technologies, the protection provided by the equipment may be impaired.



The UV LED Head operation can be affected if handled incorrectly. Never touch the protective lens cover assembly of the UV LED Head. The presence of skin oils may result in a decrease in system performance.



Always ensure the power supply unit is turned off prior to disconnecting or re-connecting the UV LED Head.



Warning:
Monitoring the system during automated operation:

The level of UV energy supplied by the OmniCure® AC9- is sufficient to ignite flammable substances. Therefore, when the unit is operated unattended in an automated environment, an alarm function must be provided by the user to indicate a malfunction in the associated equipment used. During installation the appropriate measures must be included to prevent any such occurrence.

3 Optical Safety Data

IEC 62471: Photobiological Safety of Lamps and Lamp Systems

Resulting Classification and Labelling

Hazard	AC9150/ P-395 AC9225/ P-395 AC9300/P-395
Actinic UV	Risk Group 3
Near UV	Risk Group 3
Blue Light	Risk Group 1
Retinal Thermal	Risk Group 2

<p>GROUPE DE RISQUE 3</p> <p>AVERTISSEMENT : Ce produit émet des UV. Eviter d'exposer vos yeux et peau à un produit non blindé.</p> <p>ATTENTION : Radiations optiques nuisibles peuvent être émises de ce produit. Ne pas fixer une lampe en cours d'utilisation.</p>		<p>RISK GROUP 3</p> <p>WARNING: UV emitted from this product. Avoid eye and skin exposure to unshielded product.</p> <p>CAUTION: Possibly hazardous optical radiation emitted from this product. Do not stare at operating lamp.</p>
<p>IEC/TR 62471-2:2009</p>		

4 Getting Started

4.1 Packaging Contents

The package contains one of the following UV LED Heads, as well as a quick start reference guide:

Model	Array Curing Width	Part Number
AC9150-395nm	150 mm	019-00241R
AC9150P-395nm	150 mm	019-00252R
AC9225-395nm	225 mm	019-00255R
AC9225P -395nm	225 mm	019-00253R
AC9300-395nm	300 mm	019-00247R
AC9300P-395nm	300 mm	019-00246R
AC9225F-395nm	225mm	019-00356R

Replacement air filters (qty: 10) can be ordered from Excelitas Technologies. Carefully unpack the unit and store the packing material for future use.

4.2 System Requirements

In addition to the UV LED Head, the following components are required:

- Power supply
- Power cable

Note: You will also require a PLC controller unless you are using an existing controller. The PLC controller is used to discover the extensive functionality of the UV LED Head, but integrators can access the full feature set through integrating with the PLC interface directly. Refer to [Section 6.1](#).

These components may be sourced separately or may be purchased from Excelitas Technologies. Check with Excelitas Technologies to determine the appropriate components for your requirements. The following table provides the part numbers of recommended component parts.

Standard	AC9150 – 395nm	AC9225 -395nm	AC9300-395nm
UV Head	019-00241R	019-00255R	019-00247R
System Controller	019-00211R	019-00211R	019-00213R
DC Power Cable	018-00595R	018-00595R	018-00595R
PLC2000 controller ¹	019-00214R	019-00214R	019-00214R
Print	AC9150P – 395nm	AC9225P-395nm	AC9300P-395nm
UV Head	019-00252R	019-00253R	019-00246R
System Controller	019-00211R	019-00211R	019-00213R
DC Power Cable	018-00595R	018-00595R	018-00595R
PLC2000 controller ¹	019-00214R	019-00214R	019-00214R
Optical Fiber	AC9225F -395nm		
UV Head	019-00356R		
System Controller	019-00211R		
DC Power Cable	018-00595R		
PLC2000 controller	019-00214R		

4.3 Connecting the Power Supply and PLC Controller

Note: All connectors are via screw style fastener -- do not over tighten the connector screws.

Note: The following is a generic procedure, illustrated with the common components described above; please refer to specific documentation related to your power supply and controller.

Tip: After securing the power cable to the power supply, it is recommended to "tie-off" the female connector cable on to the mounting brackets or process rigging as a form of strain relief.

1. Make sure the power supply unit is turned off.
2. Connect the AC power cord to the power supply.
3. Attach the male end of the power cable to the power supply unit, and connect the female end of the power cable to the UV LED Head per Figure 1 – AC9300 shown.

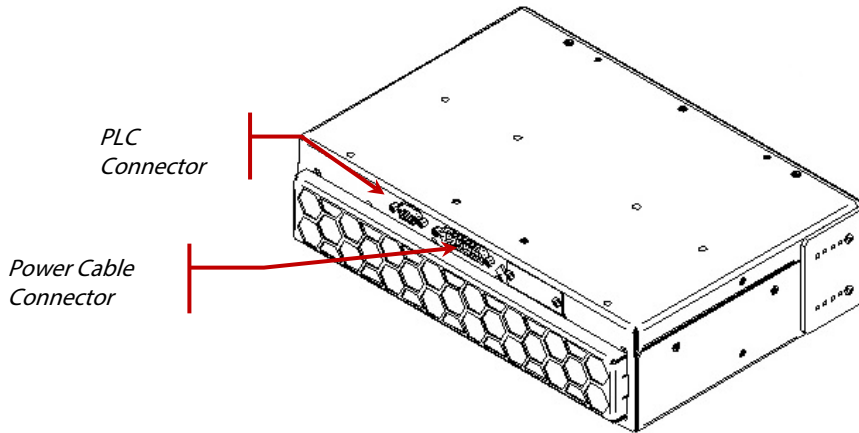

Figure 1 UV LED Head Connection Ports

4. Connect the PLC loop-back connector to the PLC pass-through port (see [Figure 2](#))
5. Power up the UV LED Head per [Section 4.4](#), and then push the LED Enable button on the controller to turn power on to the LED Head.
6. Adjust intensity using the up or down buttons to the right of the display (see [Figure 2](#)) to increase and decrease the intensity respectively. Refer to [Section 6](#), "Using the LED Head".
7. UV LED & Temperature faults will be indicated by an illuminated LED on the control console. To clear, press the Clear Fault button (see [Figure 2](#)).



Figure 2 PLC2000 Remote Control Console

4.4 Powering Up and Powering Down



1. Ensure that the ACg- system has been properly installed and the UV LED Head is securely mounted with the optical lens in the desired orientation. Refer to [Section 5](#), "Mounting the UV Head".
2. Verify that the power supply unit's AC supply cord is connected to a properly grounded AC outlet.
3. If the power supply has a circuit breaker, switch it to the "ON" position.
4. Turn the main power switch of the power supply to the "ON" position and check the fan for airflow.
5. The LED indicator on the UV LED Head will *flash* green during "boot-up" and change to a *steady* green indicating UV LED Head is ready for use. It is recommended to wait for 15 seconds from initial power-up before attempting to control the UV head. For more information about the indicators, see [Section 7.1](#), "Understanding the LED Indicators".



After turning on UV power, the system will reach a fully stable operating temperature in 2-3 minutes. Caution – the UV LED Head can become very hot, avoid handling until the UV LED Head has cooled down (approx. 5 min) or use protective gloves.

Before disconnecting any cables, power down the UV LED Head using the PLC controller and turn off the power supply. (Note: the cooling fan may take up to 10 seconds to stop).

5 Mounting the UV Head

5.1 UV LED Head

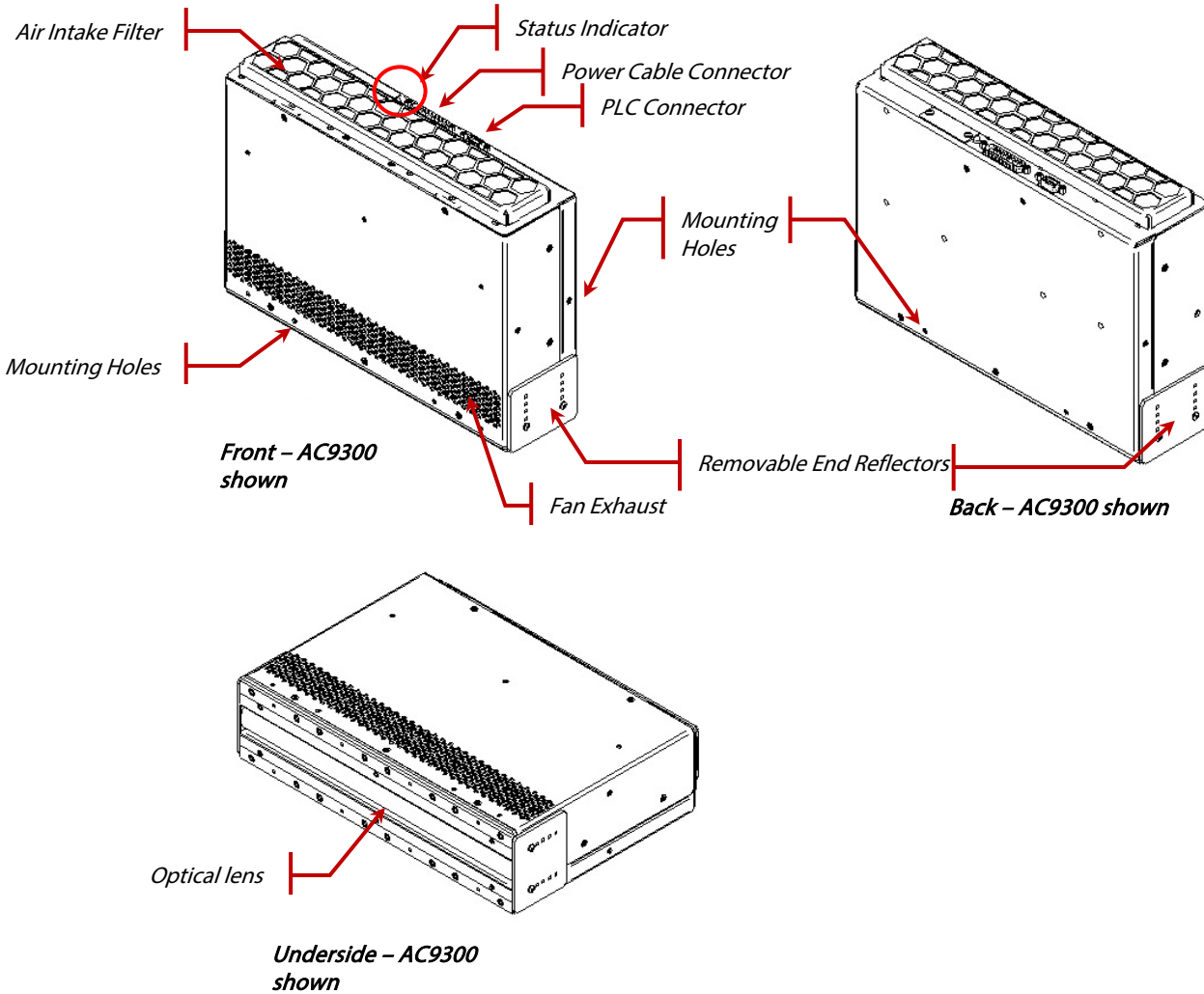

Figure 2 UV LED Head

5.2 Mounting the UV LED Head



****WARNING****

Do not block the air intake or the exhaust fans for the UV LED module's cooling system. Ensure that both intake and exhaust vents located on the LED heads have at least 5 inches (12cm) of clearance to allow sufficient air flow.

The UV LED Head includes threaded mounting holes (on the front, on the back, and on each side panel) M4 X 6mm deep. Mounting hole locations on the side panel are identical for all AC9- models. However, front and back mounting hole locations differ according to the model. Refer to [Figure 2](#) above and mechanical drawings for more information (www.excelitas.com/omniure).

Never mount the system using only one row of mounting features or from one side as this may damage the unit.

For applications requiring adjoining UV LED heads, mounting rails can be constructed from two long L-brackets. **Remember in adjoining-head applications to remove the end-reflectors from all head-head abutment regions to maximise head-head optical uniformity.** The end-reflectors on the end-most points of the optical line can remain in place to further extend uniform operating length and operate as a UV shield for operators.



****CAUTION****

The threaded mounting holes in the AC9- incorporate a blind configuration; ensure that the appropriate length of mounting hardware is used. Attempting to install over-length mounting screws could damage the threaded mounting holes and internal components.

5.3 Adjusting the Side Reflectors

To improve the longitudinal uniformity at the ends of the UV light line, the AC9- series products are equipped with adjustable end reflectors (see [Figure 2](#)). These reflectors can be lowered in 10mm increments and can provide about 15mm of extended useful length when fully extended to 30mm working distance. They may also be useful in providing additional operator shielding of UV light.

To gain best effect from this mechanical feature, ensure that in the intended installation location the reflectors will not interfere with conveyed parts or conveyor belt or other mechanical attachments. Failure to do so may result in damage to ancillary hardware or the UV LED Head itself.

To adjust the reflectors:

1. Ensure that power to the unit is switched off.
2. Remove the two screws holding the end reflector in place.
3. Move the reflector down to the desired position, insert and tighten the two retaining screws.

This operation can also be performed on a single head.



****CAUTION****

When the end reflectors are detached from the head, the ends of the optical assembly and LED modules can be physically accessed. Take extreme care not to allow fingers, tools or other foreign objects or debris to come into contact with these areas. Doing so may severely damage or impair the function of your AC9-series UV LED head. The installer should minimise the amount of time or frequency that these regions of the LED head are left unprotected.

5.4 UV LED Head Dimensions

The dimensions and weights of the various AC9 Series models are outlined below:

	AC9150 / AC9150P	AC9225 / AC9225P/AC9225F	AC9300 /AC9300P
	395 nm		
Dimensions (LxWxH)	159 x 80 x 218mm	235 x 80 x 218mm	311 x 80 x 218mm
Weight (kg)	1.8	2.7	3.6

The mechanical drawings for each of the standard ACg products are enclosed in this manual, in [Figure 3](#), [Figure 4](#), and [Figure 5](#) respectively. Note that print versions are 4mm shorter in height. For ACg Series print version drawings or additional details or mechanical drawings for other ACg series models, please visit us online at www.excelitas.com/omnicure.

For reference, the ACg300, ACg225 and ACg150 mechanicals can be found below.

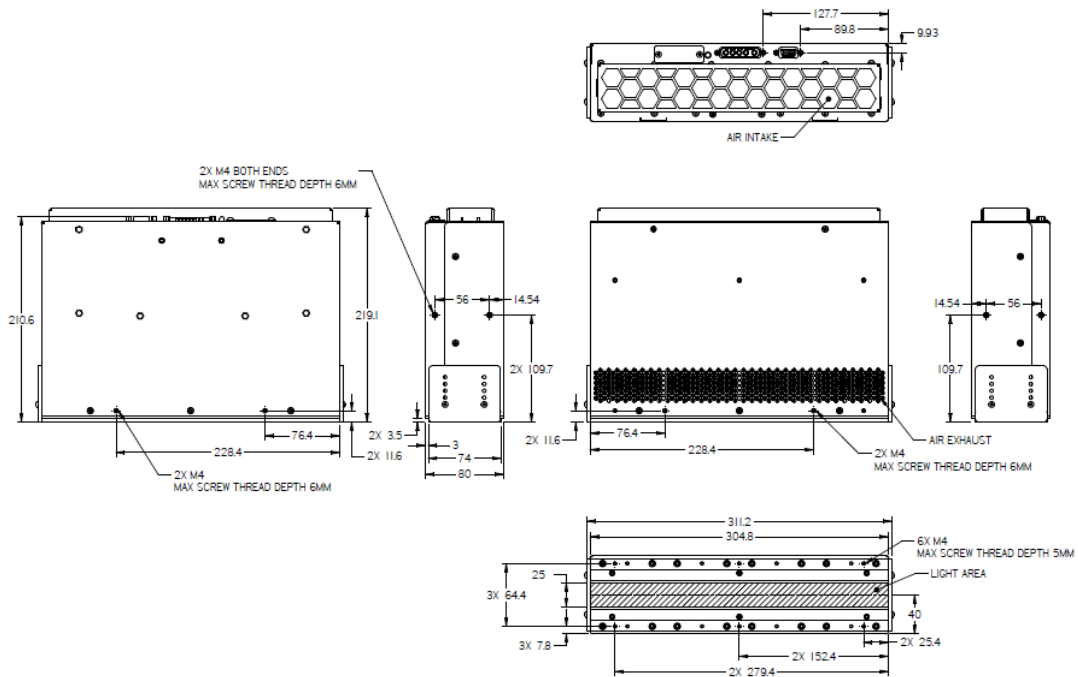

Figure 3 AC9300 UV LED Head Mechanical Drawings

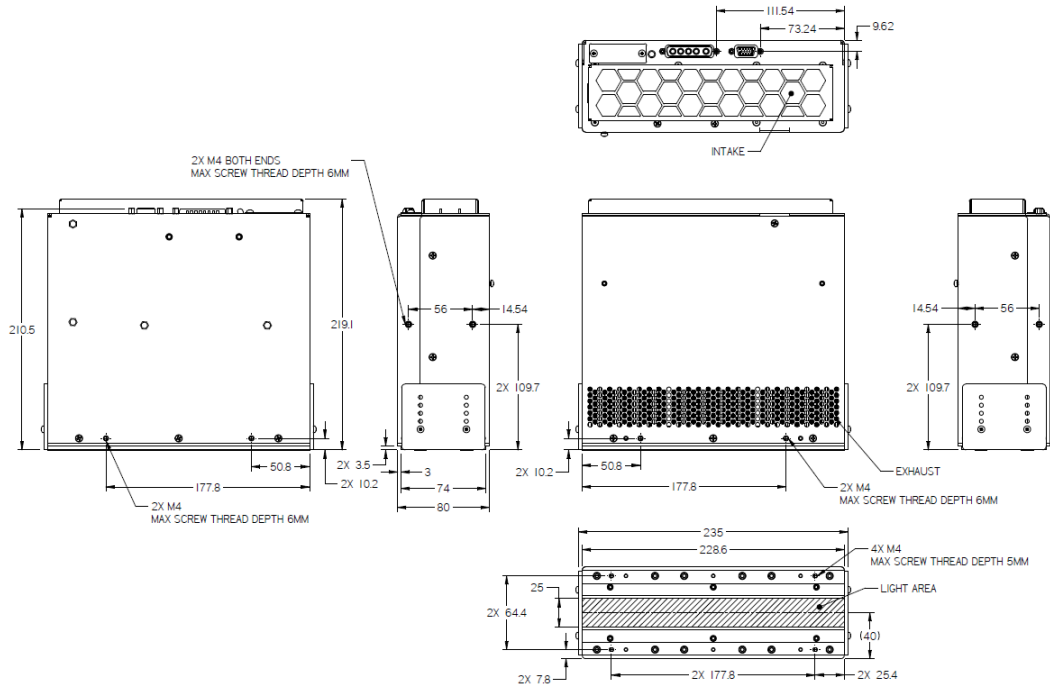

Figure 4 AC9225 UV LED Head Mechanical Drawings

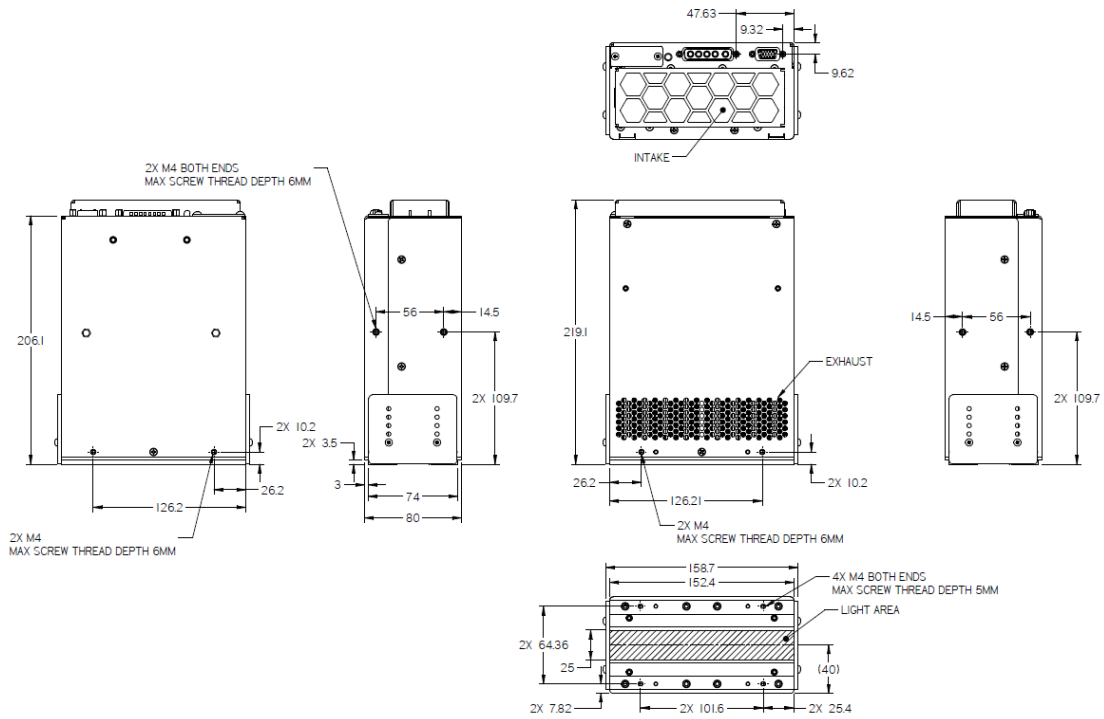

Figure 5 AC9150 UV LED Head Mechanical Drawings

6 Connecting the UV LED Head

6.1 Interfacing with the System Controller (PLC)

PLC Input Signal Requirements

	Digital	Analog
Input	<ul style="list-style-type: none"> Voltage: 0 – 24V Current: 1 – 40mA 	<ul style="list-style-type: none"> Voltage: 0 – 5V Current: 500uA
Output	<ul style="list-style-type: none"> Voltage: 0 – 5V Current: 2.5mA (max.) 	<ul style="list-style-type: none">

PLC Connector Pin-Out

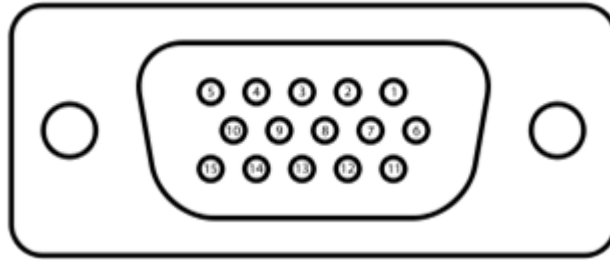

Figure 6 PLC Connector (looking at UV Head)

PIN	Name	Description
1	Intensity Input	Input voltage is converted to required current to achieve desired intensity; intensity will vary linearly between 20% and 100% for voltages between 1V and 5V respectively. A minimum voltage of 0.4V is required for proper light source operation. If the user inputs a voltage <i>below</i> the minimum required, the light source will not turn on.
2	Enable High	0.0V to +0.6V = Turns LEDs off (Open input will default to OFF). +2.4V to +24.0V = ON.
3	Enable Low	0.0V to +0.6V = Turns LEDs on. +2.4V to +24.0V = Turns LEDs off (Open input will default to OFF).
4	Thermal Fault	0.0V to +0.4V (ground) = Fault +2.4V to +5.0V (open) = No Fault
5	IsoDGND	Ground Reference for digital IOs
6	IsoVCC	+5.0V Output.
7	Reserved	Do not connect
8	Door Lock *	0.0V to +0.6V = UV Emission Allowed. +2.4V to +24V = UV Emission Stopped.
9	IsoGND	Ground Reference for analog IOs.
10	LED ON	0.0V to +0.4V (ground) = LED off +2.4V to +5.0V (open) = LED on.
11	Reserved	Do not connect
12	UV LED Fault	0.0V to +0.4V (ground) = Fault +2.4V to +5.0V (open) = No Fault
13	Reserved	Do not connect

PIN	Name	Description
14	Clear Fault/ LED Hours	High-to-low transition clears faults; low-to-high transition initiates visual indicator sequence of accumulated LED hours
15	Temperature Monitor	Output is a voltage proportional to the maximum UV LED heat sink temperature. Conversion Factor: 0.05V/°C.

Table 1 PLC Connector Pin Out

6.2 Integrating Monitoring with External Circuitry

All inputs and outputs from the PLC interface are opto-isolated. The digital outputs are implemented using NPN logic. The equivalent circuit is shown in Figure 7 below

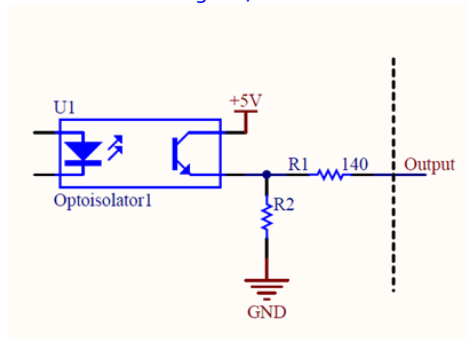

Figure 7 PLC Digital Output Equivalent Circuit

6.3 Interfacing with the Power Cable

Please note that the 5 conductor DC power cable (018-00595R) must be used with the AC9 series UV LED heads. The 3 conductor power cables (019-00559R) used with other AC Series will not work with the AC9 Series.

Should third party cable assemblies be used, please note the following specifications must be met in order to ensure reliable operation of the AC9 series UV LED heads and guarantee the appropriate EMI/EMC requirements are met.

AC9300 /: 5 conductor 12AWG, shielded cable less than 5 meters in length.

AC9225 / AC9225P: 5 conductor 14AWG, shielded cable less than 5 meters in length.

AC9150/ AC9150P: 5 conductor 16AWG, shielded cable less than 5 meters in length or 3 conductor 12AWG, shielded cable less than 5 meters in length (connect one of pins A1 or A2, one of pins A3 or A4, and A5).

AC9225F: 5 conductor 14AWG, shielded cable less than 5 meters in length.



Figure 8 Power Connector (looking at UV Head)

PIN	Name	Description
A1,A2	+ve	48V DC power feed
A3,A4	-ve	48V DC power return
A5	Chassis	Chassis ground connection

Table 2 Power Connector Pin Out

48V Input Requirements:

- Voltage: 46-50V DC
- Current: AC9150/P=23A; AC9225/P=34.5A;; AC9300/P=45.5A; AC9225F=26.3A

Note: For safety, the AC9 Series is internally fused. These fuses are not replaceable. If it is suspected that an internal fuse has blown, please contact [Excelitas Technologies Service Centre](#) for further assistance and refer to [Sections 12 and 13](#) of this manual.

7 Using the LED Head

The peak wavelength of the UV LED Head is 395nm +/- 5nm, depending on model.

For all models, adjusting the UV LED Head intensity can be actuated by an external controller via the PLC interface. Refer to [Section 6](#) for Pin-Outs.



Input voltage vs. desired intensity; 5V = 100% and 1V = 20%. A minimum voltage of 1V is required for light source operation.

Note: The light source will maintain a 20% intensity when the input voltage is in the range of 0.5V. If the input voltage is below this, the light source will turn off.

Ensure the UV LED Head indicator is illuminated to a *steady* green before applying UV power to the head. The UV LED Head indicator will illuminate to a *steady* amber indicating UV is on. When UV is off, the indicator will revert back to a *steady* green indicating UV is off.

The UV LED Head is capable of responding to PLC control signals in less than 0.2 seconds.

7.1 Understanding the LED Indicators

LED Indicator	Condition
Steady green	System Ready; no critical faults
Steady amber	UV LED turned ON
Steady red	Critical fault <ul style="list-style-type: none"> • Temperature Fault • LED Fault • System Error
Slow flashing green (~1x/second)	POST and Initialization Input voltage is less than 46V or greater than 50V. Unit is still functional.
Slow flashing red	Major and critical fault
Slow flashing amber	UV LED ON with 48V input voltage out of requirement
Fast flashing green (~3x/second)	Warranty status - operating hours is < 9,000
Fast flashing amber	Warranty status - operating hours = between 9,000 and 10,000
Fast flashing red	Warranty status - operating hours is >10,000

Table 3 LED Indicator Status (UV LED Head)

A transition from high-to-low is required to clear the alarm signals. Use the PLC function:

Pin #	Description	I/O	Behaviour
14	Clear fault/ LED hours	In	0V to 0.6V (Open) Logic Low 2.4V to 24V Logic High High-to-low transition = clear faults Low-to-high transition = LED hours

Caution: Routine maintenance should only be completed by a user qualified personnel to avoid risk of injury to the end user. **No user serviceable components are located within the power supply or UV LED Head enclosures.**

7.2 Fault Status

PLC Output

- LED Fault: At least one module fails to turn on.
- Thermal Fault that includes:
 - At least one module's temperature is over the maximum limit.
 - At least one module's temperature is lower than the minimum limit or open circuit.
 - Internal Fault.

8 Troubleshooting

8.1 Symptoms and Possible Causes

Service to be completed by qualified Excelitas Technologies personnel only!

Always wear optical safety glasses while troubleshooting. Never put hands or fingers in front of the lens. Serious personal injury may result.

Do not place any potentially combustible materials (e.g. paper, card, etc.) in front of the LED Head. Risk of fire and damage to the UV LED Head may result.

If the system fails to power up:

- Make sure the AC power cord is securely plugged into a functional AC outlet and into the AC inlet on the power supply unit.
- Make sure that the circuit breaker on the power supply unit is not tripped. If so, reset breaker.
- Make sure all cable connections (power supply to UV LED Head) are secure.
- Ensure that the power supply is switched on and the green LED indicator on the front panel is lit.
- Make sure the door lock electrical loopback on the PLC is installed properly.

If the system powers up but experiences a thermal fault during operation:

- Ensure UV Head is installed with adequate clearance around intake and exhaust ports.
- Ensure intake air filter is not clogged or obstructed.
- If filter is clogged, either clean with compressed air or replace with a new filter insert.

If the system powers up but does not emit UV:

- Check that the door lock loop is intact.
- Ensure that the voltage levels on pins 2 and 3 of the PLC interface match the logic required to enable the LEDs.
- Check the visual indicator for signs of a fault.

If a fault condition has been detected:

- Attempt to clear the fault by toggling the voltage high on pin 14 of the PLC interface or by pressing the "Clear Fault" button on the PLC controller.

If the system exhibits a fault condition with a slow-flashing red:

- Power-cycle the UV Head to clear.

If the light intensity is too low:

- Make sure the input voltage is at least 46V (input voltage to the Head for the purposes of powering the head is typically 48V (46-50V DC)).
- Out-of-range input voltage will be indicated on the visible indicator on the UV LED Head with a slow flashing green.
- Clean the optical window of the UV LED Head as described in [Section 9.3](#), "Cleaning the LED Head".
- Verify that the intensity level of the UV LED Head is set to the correct level, using the PLC Controller.

If problems persist beyond these troubleshooting points, please contact Excelitas Technologies Service Department (refer to [Section 13](#), "Contact Information").

9 Care and Maintenance

Note: Excelitas Technologies recommends incorporating the cleaning of the optical lens into the user/operator cleaning and maintenance schedule.

9.1 Cautions and Handling



Caution: Routine maintenance should only be completed by qualified personnel to avoid risk of injury/electrical shock to the end user. **No user serviceable components are located within the UV LED Head enclosure.**



Warning: Use UV radiation eye and skin protection during servicing if access to the UV LED modules is required during operation.

Risk Group 3 (IEC62471)

WARNING: UV emitted from this product. Avoid eye and skin exposure to unshielded product.

CAUTION: Possibly hazardous optical radiation emitted from this product. Do not stare into operating lamp.



CAUTION UV: Hazardous visible radiation is emitted from this product. Eye or skin irritation may result from exposure. Use appropriate shielding.

Ensure main power supply is disconnected prior to making any changes to cabling configurations.

Ensure that both intake and exhaust vents located on the LED heads have at least 5 inches (12cm) of clearance to allow sufficient air flow.

Avoid physical shocks or jarring of the LED Head, especially while the unit is operating.

When necessary, clean the optical lens of the UV LED Head using an optical cleaning solution. Refer to [Section 9.3](#), "Cleaning the LED Head".

The UV LED Head includes an optical lens assembly. Improper handling and cleaning practices can damage polished surfaces or coatings which are utilized in this optical lens. Note that damage to the surface of the glass or coating can degrade the unit's performance. Proper handling and cleaning technique is very important. Below are the recommended procedures for cleaning of the OmniCure® UV LED Head optical lens.

Always handle the UV LED Head by the metal enclosure; never touch the optical lens with your fingertips. The moisture or oils on your fingertips can damage the coating of the lens. Fingerprints left on an optical surface for an extended period of time, can become a permanent stain. Even if you are wearing gloves, avoid touching the optical surface.

Never touch the optical lens with metal implements or tweezers.

Do not place the UV LED Heads lens assembly down onto a hard tabletop surface; this can cause scratches in the lens surface.

To store UV LED Heads, wrap them individually in a clean, lint free bag and store in a safe place, preferably using the original packaging.

Never store unwrapped LED Heads together in a box or bag, as they may become damaged if they come in contact with each other.

9.2 Cleaning Materials

- Lint-free lens tissue, lint-free cotton swabs, lint or powder-free gloves or finger cots.
- An organic solvent, such as reagent-grade isopropyl alcohol, reagent-grade acetone, or lens cleaning solution.

9.3 Cleaning the LED Head



****WARNING****

Do not attempt to open the enclosure of the LED head. Ensure power to the power supply unit is OFF and the UV LED arrays are cool before attempting any cleaning procedure.

Use protective gloves or finger cots suitable for the cleaning solution selected. Refer to the MSDS for guidance.

Turn off the UV LED Head and keep the optical lens, face down to prevent the solvent from seeping into the assembly during the cleaning procedure.

Blow off dirt and dust with pressurized air on front glass surface.

Use a lens tissue folded into quarters or a lint-free cotton swab. Saturate the lens tissue or swab with organic solvent as indicated in the cleaning materials section.



****CAUTION****

Before using any solvent, consult the manufacturer's Materials Safety Data Sheets (MSDS) and your internal Health and Safety Advisor for proper handling and storage.

Using a new saturated tissue; clean optical lens by gently wiping the surface with a continuous stroke in one direction.

Note: Never apply a dirty tissue or swab to the optical lens of the UV LED Head.

Note: Never face the optical lens upwards before the solvent has evaporated.

9.4 Cleaning the LED Head Air Intake



****CAUTION****

Ensure that the LED Head power cable is disconnected from the head assembly and the UV LED Head is cool to the touch.

The air intake filter is located on the exterior of the LED Head (Figure 2) and is removable for cleaning and/or replacement as required. Remove the filter frame by gently prying the frame from the clip end. Next, remove the filter media located within and clean with compressed air.

Replace the filter guard and frame prior to powering up the LED Head.

10 Technical Specifications

10.1 Environmental Conditions

Operating Conditions	
Ambient Temperature	15°C to 40°C ¹
Altitude:	3000m max.
Atmospheric Pressure:	700 to 1060 hPa
Relative Humidity:	10% to 80% (non-condensing)
Installation Category	II
Pollution Degree	2
Transport and Storage Conditions	
Temperature	-20 to +75°C
Relative Humidity	0% to 80% (non-condensing)
Atmospheric Pressure	500 to 1060 hPa

Table 4 Environmental Conditions

10.2 UV LED Head Specifications

Specification	AC9150 / AC9150P		AC9225 / AC9225P/AC9225F			AC9300 / AC9300P	
	019-00241R	019-00252R	019-00255R	019-00253R	019-00356R	019-00247R	019-00246R
LED Peak Wavelength	395nm						
Estimated LED Life	>20,000 hrs			>40,000 hrs		>20,000 hrs	
Maximum Peak Irradiance	14W/cm ²			20W/cm ²		14W/cm ²	
Variable Intensity Range	20 – 100%						
Typical Working Distances	1-30mm	1-5mm	1-30mm	1-5mm	10-15mm	1-30mm	1-5mm
Active Optical Area	25 x 150mm		25 x 225mm		15x225	25x300mm	
Longitudinal Uniformity	Better than +/- 10%						
Operating Voltage	48V DC +/-2V						
Maximum Operating Current	23A		34.5A		26.3A	45.5A	

Table 5 UV LED Head Specifications

10.3 Regulatory Compliance

Product Safety and Electromagnetic Compatibility

The OmniCure AC9 Series has been tested and found to comply with product safety and electromagnetic compatibility requirements. For a complete list of tests and for certification details, please contact your OmniCure representative.

CE Marking:

Council Directive 2014/35/EU	Low Voltage	
Council Directive 2014/30/EC	EMC	
Council Directive 2012/19/EU	WEEE	
Council Directive 2011/65/EU as amended by (EU) 2015/863	RoHS	

This is a class A product. In a domestic environment, this product may cause radio interference in which case the user may be required to take adequate measures.

FCC Class A Digital Device or Peripheral - Information to User

Note: This equipment has been tested and found to comply with the limits for a Class A digital device, pursuant to Part 15 of the FCC Rules. These limits are designed to provide reasonable protection against harmful interference when the equipment is operated in a commercial environment. This equipment generates, uses, and can radiate radio frequency energy and, if not installed and used in accordance with the instruction manual, may cause harmful interference to radio communications. Operation of this equipment in a residential area is likely to cause harmful interference in which case the user will be required to correct the interference at their own expense.



****WARNING****
Changes or modifications not expressly approved by Excelitas Technologies could void the user's authority to operate the equipment.

10.4 China RoHS



The symbol above indicates that this product is in compliance with China RoHS requirements.

Part Name	Hazardous Substances
-----------	----------------------

	Lead (Pb)	Mercury (Hg)	Cadmium (Cd)	Hexavalent Chromium (Cr (VI))	Polybrominated biphenyls (PBB)	Polybrominated diphenyl ethers (PBDE)
Printed Circuit Board Assemblies	X	O	O	O	O	O

This table is compiled according to SJ/T 11364.

O : Indicates that the content of the hazardous substance in all homogeneous materials of the part is below the limit requirement of GB/T 26572.

X : Indicates that the content of the hazardous substance in at least one of the homogeneous materials of the part exceeds the limit requirement specified by GB/T 26572.

10.5 WEEE Directive



The symbol above indicates that this product should not be disposed of along with municipal waste, that the product should be collected separately, and that a separate collection system exists for all products that contain this symbol within member states of the European Union.

The equipment that you bought has required the extraction and use of natural resources for its production. It may contain hazardous substances that could impact health and the environment.

In order to avoid the dissemination of those substances in our environment and to diminish the pressure on the natural resources, we encourage you to use the appropriate take-back systems. Those systems will reuse or recycle most of the materials of your end life equipment in a sound way.

The crossed-out wheeled bin symbol indicated above invites you to use those systems.

If you need more information on the collection, reuse and recycling systems, please contact your local or regional waste administration

11 Accessories

Various accessories to enhance the application utility of the AC9-series are available. Please contact Excelitas Technologies for more information.

12 Warranty

Excelitas Technologies warrants the original purchaser for a period of one (1) full year, calculated from the date of purchase, that the equipment sold is free from defects in material and workmanship.

In the event of a claim under this warranty, the equipment is to be sent postage and carriage paid to the [Excelitas Technologies Service Centre](#). Returned equipment will not be received without a Return Authorization (RA) Number, issued by the appropriate Service Centre.

In order for us to serve you better, include a written description of the fault and the name and telephone number of a contact person who may be contacted for additional service related questions.

Any claims for units received with defects in material or workmanship must be reported to an authorized Excelitas Technologies Service Centre within 30 days from the original date of receipt and returned within 30 days of reporting to a an authorized Excelitas Technologies Service Centre. Excelitas Technologies will repair or replace these reported defects free of charge. The equipment must be sent postage and carriage paid.

Package the equipment in its original shipping case or as appropriate to prevent damage during transport.

In the case of damage caused by wear and tear, careless handling, neglect, by the use of force or in the case of interventions and repairs not carried out by an Excelitas Technologies Authorized Service Centre, the warranty ceases to be valid. This warranty may not form the basis for any claims for damages, in particular not for compensation of consequential damages.

This warranty is not transferable.

No warranty is extended to perishable items (if purchased separately or included in systems). These may include, but are not limited to air filters and cables.

****WARNING****

*Apart from filters there are no field serviceable parts within the equipment.
Opening the equipment main enclosure will void the warranty.*

12.1 Checking Your Lamp Hours

Level transitions on pin 14 of the PLC interface can be used to access the UV LED warranty status information:

Pin #	Description	I/O	Behaviour
14	Clear fault/ LED hours	In	0V to 0.6V (Open) Logic Low 2.4V to 24V Logic High Low-to-High transition = LED hours

You can also check the status by pressing the Clear Fault button on the PLC Controller: on release of the button, the warranty status is indicated on the status indicator on the UV LED Head.

The LED indicator on the UV Head will display the warranty status of the UV LEDs as follows:

LED Indicator	Condition
Fast Flashing Green	Operating hours is < 9000
Fast Flashing Amber	Operating hours = between 9,000 and 10,0000
Fast Flashing Red	Operating hours is >10000

Table 6 UV LED Warranty Status

12.2 Replacement UV LED Module Warranty

If the AC9- system fails to power up during the warranty period of 10,000 operational hours or 2 years, whichever comes first, the UV LED Module will be replaced under warranty. In the event of a claim under this guarantee, the UV LED Head is to be sent postage and carriage paid, including a description of the fault, to the nearest [appropriate Excelitas Technologies Service Centre](#). Returned equipment will not be received without a Return Authorization (RA) Number, issued by the Service Centre. This warranty is non-transferable.

In the case of damage caused by careless handling, neglect, by the use of force or in the case of interventions and repairs not carried out by an Excelitas Technologies Service Centre to the AC9- system, the guarantee ceases to be valid.

12.3 Returning your AC9- System to Excelitas Technologies for Service

Please make a note of the problem encountered, the steps followed to isolate the problem and the result of any trouble shooting steps taken.

Telephone the nearest Excelitas Technologies Service Centre to obtain a Return Authorization Number so that repairs may be completed quickly and efficiently. In North America, request for Return Authorization number can be made online at https://www.excelitas.com/ox_service_request_form

Enclose details of the problem with the unit and return both to the Excelitas Technologies Service Centre. The unit should be returned in its original packaging if possible.

Include a phone number and contact person who may be reached for any additional service-related questions.

13 Contact Information

Excelitas Canada Inc.
2260 Argentia Road
Mississauga, Ontario
L5N 6H7 CANADA

Tel.: +1 905 821-2600

Toll: +1 800 668-8752 (USA and Canada)

Fax: +1 905 821-2055

http://www.excelitas.com/Pages/Contact/Contact_OX.aspx

www.excelitas.com/omnicure

Technical Assistance:

Techsupport@excelitas.com

https://www.excelitas.com/ox_service_request_form

For a complete listing of Authorized OmniCure Distributors and Service Centres please go to
<https://www.excelitas.com/dealer-search>